Table of Contents

Electronic Signals and Components

Subject	Page
Semiconductor Technology	4
N-Doping	5
P-Doping	5
Junctions	5
Electronic Components	7
Diodes	7
Light Emitting Diode	8
Z-diode	9
Transistor	9
Functional Principle	10
Transistor as a Switch	11
Field-effect Transistors	12
PTC and NTC Resistors	13
NTC Resistor	13
PTC Resistors	14
Capacitors	15
Charging and Discharging a Capacitor	16
Capacitance	18
Charge and Discharge Time of a Capacitor	18
Resistors	19
Resistor Color Code Guide	19
Variable Resistors	20
Thermistor	20
Potentiometer	20
Rheostat	20
Integrated Circuits	21
Integrated Circuit Manufacturing	21
Control Units	22
Purpose of Electronic Signals	23
AC Voltage Signals	24
Inductive Signals (Induced Voltage)	24
DC Voltage Signals	25
DC Analog Signals	25

Subject	Page
DC Analog Sensors25
NTC Sensors25
PTC Sensor26
Potentiometers27
DC Digital Voltage Signals28
Switched B+ (High/Low) Signal28
Switched B- (High/Low) Signal29
Modulated Square Wave30
Frequency30
Pulse Width31
Duty Cycle31
DC Digital Sensors32
Hall Effect Sensors32
Magnetoresistive Sensors33
Designated Value Signals35
Coded Ground Signals36
DC Digital Input/Output Stages37
Transistor Final Stage Function37
Modulated, Momentary, Constant B- as Input/Output38
Momentary/Constant B+ as an Input/Output Signal38
Constant B-/B+ to Energize a Component39
Modulated B-/B+ to Operate a Component40

Electronic Signals and Components

Model: All

Production: All

OBJECTIVES

After completion of this module you will be able to:

- Identify the different types of electronic components used.
- Understand the different signals and their testing procedures.
- Explain the operation of an Inductive Sensor.
- Understand the difference between analog and digital signals.
- Know the difference between NTC and PTC type sensors.
- Explain the operation and use of different types of signals
- Recognize signal types on the oscilloscope.

Semiconductor Technology

Semiconductors are materials whose conductivity is between that of metals with very good conductivity and insulators. Semiconductors are contaminated for the purpose of specifically influencing or controlling their conductivity. In technical terms this is referred to as doping. The doping process involves incorporating external atoms of varying valency in a defined crystal structure.

The conductivity of semiconductors is low at room temperature. The conductivity changes by subjecting semiconductors to energy in the form of heat, light, voltage or magnetic energy. The sensitivity of semiconductors to pressure, temperature and light also makes them the ideal material for sensors.

Semiconductor components are mainly produced from the semiconductor materials silicon (Si) and gallium arsenide (GaAs).

Germanium (Ge) was used particularly in the early years of semiconductor technology as the raw material for manufacturing transistors but is of little significance today due to its low boundary layer temperature of 75 °C.

A silicon crystal comprises a solid structure of individual silicon atoms. Each atom has 4 electrons in its outer shell, known as valent electrons. On each side of the atom, a valent electron combines with the corresponding electron of the neighboring element to form an electronic compound. In this way, each atom forms 4 fixed electron pair bonds with the respective neighboring atom.

In its solid state, pure silicon therefore forms a crystalline lattice which has high-resistance characteristics, i.e. it is a poor conductor.

The conductivity of the pure silicon crystal can be increased by specifically contaminating it with substances of higher or lower valent. The incorporation of external atoms in the silicon crystal lattice is known as "doping".

Semiconductors are doped for the purpose of specifically influencing or controlling their conductivity. A distinction is made between p-doping and n-doping depending on the element that is added to the pure silicon.

A boundary layer known as the pn-junction is produced by combining p-conductive and n-conductive material.

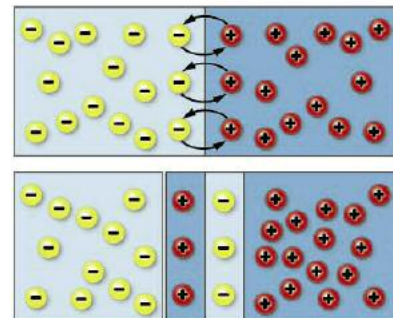

N-Doping

When contaminating a silicon crystal with a pentavalent element such as phosphorous, the phosphorus atom can easily slip into the silicon crystal structure. However, a phosphorus atom has five valent electrons, of which only four can form a fixed electron pair bond with the neighboring silicon atoms.

One free electron therefore remains surplus.

The phosphorus atom that was incorporated in the silicon crystal therefore forms an imperfection with a surplus electron. The crystal dopes in this way is an n-semiconductor.

In practical applications, the structure is formed such that one phosphorus atom is added to every million silicon atoms. The degree of doping of the silicon with phosphorus is therefore very weak.

This type of doped material is called negative or N-material, because it already has excess electrons and will repel additional negative charges.

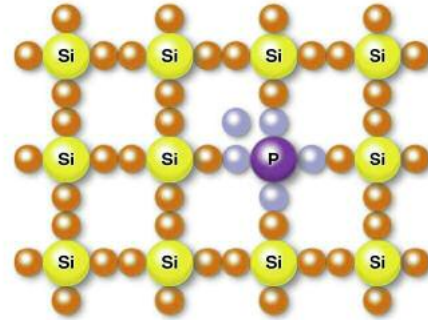

P-Doping

In the case of p-doping, a trivalent element such a boron is added to a silicon crystal. A boron atom has three electrons in its outermost electron orbit, however, it requires four electrons for it to combine with its four neighboring elements to produce a covalent atomic bond. A "hole" remains in the place where an electron is missing. The crystal doped with this electron hole is known as a p-semiconductor.

The electron holes have a propensity to absorb electrons in order to become neutral again.

This type of doped material is called positive or P-material because it will attract free electrons.

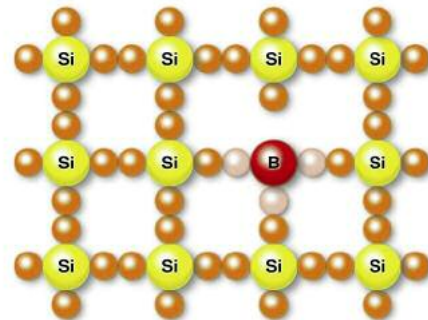

Junctions

Doping Germanium and Silicone cause them to behave in unusual but predictable ways when exposed to voltage, depending on which charge of the voltage is connected to which type of material (P or N).

The line along which joined P and N material meet is called the **Junction**. A simple component consisting of P-material and N-material joined at a junction is called a diode. The application of voltage to the two doped semiconductor materials is called biasing.

A more complex material containing two PN junctions is called a **Transistor**.

The different types of doping therefore produce two different semiconductors. By joining p-conductive material and n-conductive material a boundary layer is produced between the materials known as the pn-junction. Under the influence of ambient heat, the electrons at the boundary layer of both zones migrate from the n-semiconductor to the p-semiconductor while taking on electron holes. The electrons leave behind electron holes in the n-conductor. In this way, a space-charge zone is produced at the boundary between p- and n-semiconductors.

The electron migration is terminated when the electric field is large enough to counteract the force exerted by the thermal vibration. The higher the temperature, the wider the space charge zone and therefore the greater the electric field. An electrical voltage is produced between the space-charges. This voltage is 0.6 V to 0.7 V for silicon at a temperature of 20°C.

pn-Junction (diode) with external voltage

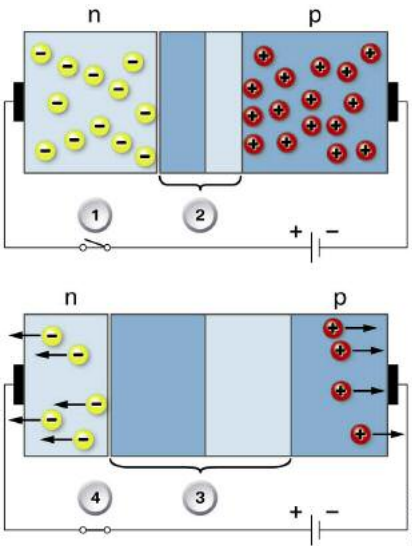

Index	Explanation
1	Open switch
2	Narrow space-charge zone
3	Wide space-charge zone
4	Closed switch

By applying the positive pole of the voltage source to the n-semiconductor and the negative pole to the p-semiconductor, the surplus electrons of the n-doped semiconductor migrate through the current source into the electron holes of the p-doped semiconductor. This increases the boundary layer (junction) and no current flows through the silicon crystal.

Electronic Components

Diodes

The component produced by joining the p-semiconductor and n-semiconductor is referred to as a semiconductor diode, abbreviated to diode.

A plastic or metal housing protects the semiconductor crystal from mechanical damage. Electrically, the two semiconductor layers are routed to the outside. The anode forms the contact with the p-layer and the cathode the contact with the n-layer.

The following graphic symbol is used in schematic circuit diagrams.

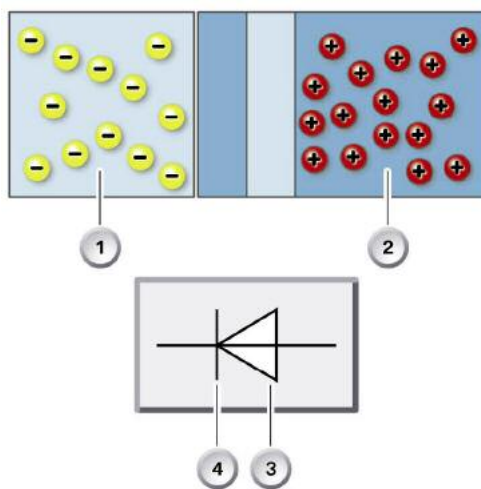

Index	Explanation
1	n-layer
2	p-layer
3	Cathode
4	Anode

The arrow shown in the graphic symbol indicates the conducting direction.

The diode acts as an electrical valve. It can therefore be used as a component for rectifying alternating current. The diode is switched in conducting direction when a positive voltage is applied at the diode and current flows through the diode. The current is limited by the load resistor to ensure it does not destroy the diode. The diode is switched in non-conducting direction when a negative voltage is applied at the anode and no current flows through the diode. An excessively high voltage in non-conducting direction can destroy the diode.



The two connections of a diode are distinguished by the identification of the "n-side" with a ring or a dot. In BMW vehicles, the diode is used both as an individual component as well as in integrated circuits in control units.

A diode acts as a valve. It has a low resistance when operated in conducting direction and a high resistance when operated in nonconducting direction. For a diode to be conductive, its anode must be more positive than the cathode by the forward voltage.

In motor vehicle electrical systems, diodes are used as rectifiers, decoupling elements, for suppressing induced voltages and as reverse voltage protection elements.

Light Emitting Diode

As other diodes, the light-emitting diode (LED) consists of two semiconductor layer, one p-layer and one n-layer. They are not made from silicon but rather from gallium arsenide.

LEDs are available in various colors (green, yellow, red, blue, ...) shapes and sizes. The color of the LED depends on the materials used.

This graphic symbol is used to denote an LED. LEDs must always be connected to a series resistor for the purpose of limiting the current that flows through the LED.

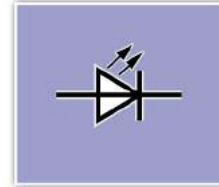

The n-layer of an LED is very strongly doped whereas the p-layer is only weakly doped. This ensures that the current is carried almost exclusively by the electrons when the diode is operated in conducting direction. Energy is released during the recombination of holes and electrons in the p-layer. Depending on the material of the semiconductor, this energy is released in the form of visible light or as infrared radiation. The light can escape as the p-layer is very thin.

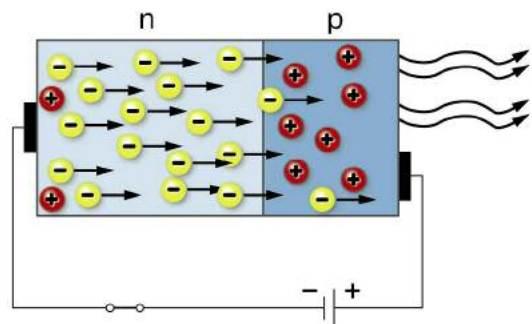

The advantages of LEDs compared to bulbs:

- Much longer service life (approx. 100 times longer)
- No sudden failure but rather decrease in light intensity over a longer period of time
- Faster response time
- Mechanically unsusceptible

Index	Explanation
1	Emitted light
2	pn- junction
3	Plastic housing
4	Electric connections

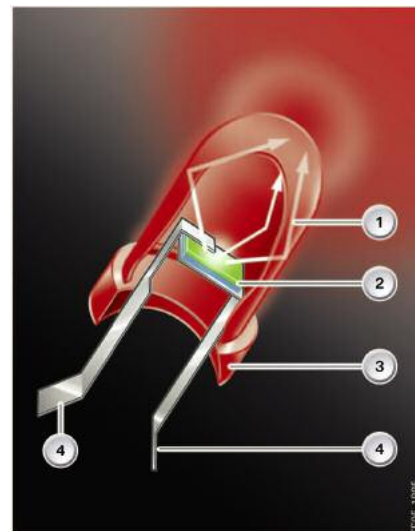

Light-emitting diodes (LEDs) are operated in conducting direction. The current must be limited by a series resistor. LEDs are used as indicators.

Z-diode

Z-diodes (Zener diodes) are operated in nonconducting direction. When a certain voltage U_Z is exceeded in nonconducting direction, the current I_Z increases substantially so that the diode becomes conductive. As the result of a high degree of doping, the nonconducting layer can be made very thin so that the breakdown already occurs at voltages between 1 V and 200 V. The current must be limited by a corresponding resistor to ensure the sharp increase in current in connection with the breakdown voltage does not destroy the diode.

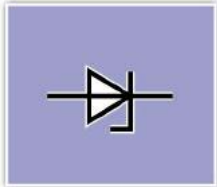

Graphic symbol of a Z-diode

Zener diodes are used in motor vehicle electronics for the purpose of stabilizing voltage and for limiting voltage peaks.

Transistor

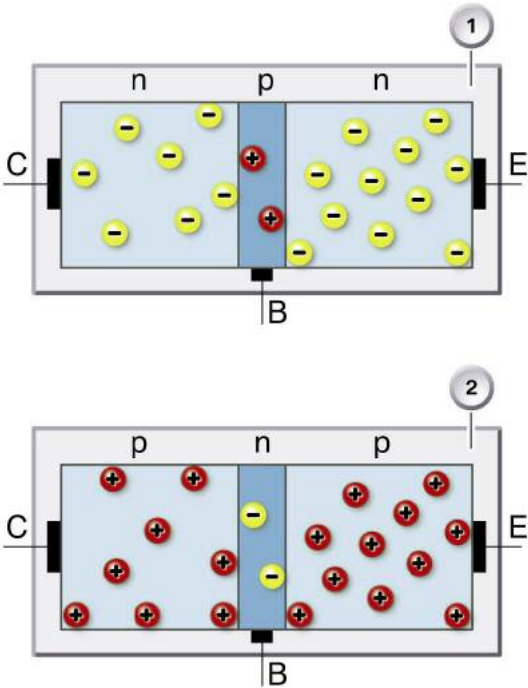

Index	Explanation
1	NPN transistor
2	PNP transistor

Transistors are electronic components made up of three semiconductor layers. Each semiconductor layer has its own electrical connection. A distinction is made between PNP transistors and NPN transistors depending on the arrangement of the semiconductor layers. The three semiconductor layers with their connections are known as emitter (E), base (B) and collector (C). The charge carriers move from the emitter to the base (they are emitted) and are received by the collector.

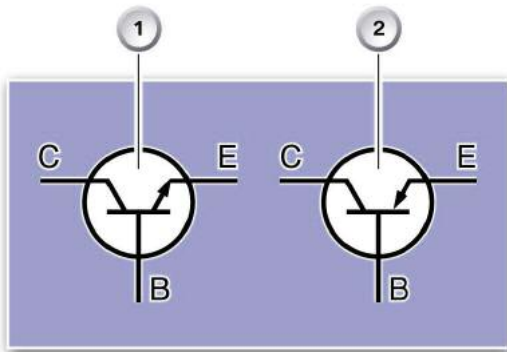

Index	Explanation
1	NPN transistor
2	PNP transistor

Transistors are electronic components consisting of three semiconductor layers. A distinction is made between PNP transistors and NPN transistors corresponding to the arrangement of the semiconductor layers.

Transistors are used for the purpose of switching small currents in motor vehicle electrical/electronic systems. The acute temperature sensitivity of semiconductors is utilized for temperature-dependent resistors.

The transistor therefore consists of two PN junctions, the one between the emitter and base and the other between the collector and base.

Functional Principle

The functional principle is explained in the following using the example of an NPN transistor. The PNP transistor operates in accordance with the same principle, however, the currents flow in the opposite direction.

The illustration in the following figure shows the principle layout of a transistor with its three connections: emitter, base and collector.

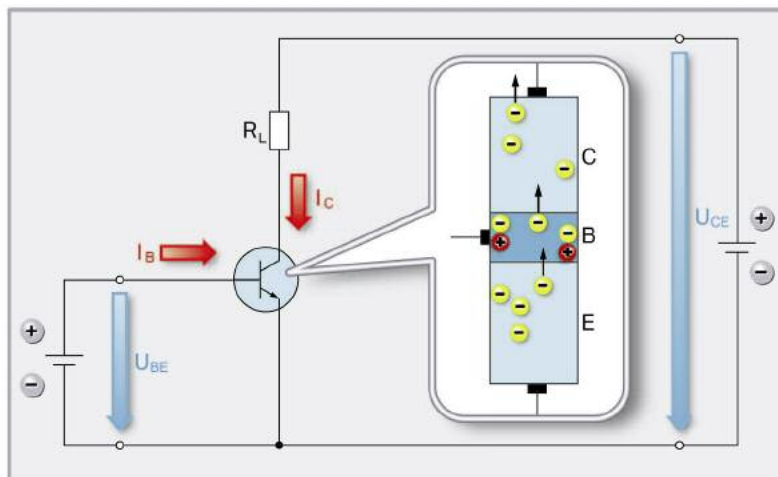

Index	Explanation
U_{BE}	Voltage between base and emitter
I_B	Base current
R_L	Load resistor
I_C	Collector current
U_{CE}	Voltage between collector and emitter

The number of electrons in the emitter is very high. There are only few holes in the base. The negatively charged electrons transfer to the base layer due to the positive voltage U_{BE} . Here, the electrons combine with the holes. Supply of the positively charged holes maintained in the form of a very small current from the base-emitter voltage source.

The remaining electrons in the base area come under the influence of the positive collector voltage when a very low voltage is applied between the collector and emitter.

The collector-base barrier layer is cancelled and a collector current I_C flows.

The boosting effect of the transistor is attributed to the fact that a very large collector current can be controlled with few charge carriers in the base area, i.e. with a very low base current.

A lower base-emitter voltage transfers only a part of the electrons in the emitter to the base so that a low collector current flows. The collector current I_C can be controlled by changing the base current I_B . The base emitter battery shown in the illustration above is replaced by a voltage divider in practical applications.

A slight change in the base current results in a large change in the collector current. In view of the largely linear relationship between the collector current and base current this change is defined as the static current gain B :

$$B = \frac{I_C}{I_B}$$

Transistor as a Switch

Electric loads in motor vehicle electrical/ electronic systems are switched on and off by means of mechanical and electronic switches. The transistor is suitable for switching very low currents.

Mechanical switches are replaced by transistors as transistors operate faster and silently and are not subject to mechanical wear.

The actual switch is the collector-emitter stage of the transistor.

No base current can flow if the transistor receives no base voltage. This therefore means that no collector current can flow. A base current and a collector current flows when the transistor receives a positive base voltage.

Field-effect Transistors

The field-effect transistor, mostly abbreviated to FET, is a unipolar transistor. Unipolar because, in contrast to the bipolar transistor considered up until now, depending on the type, either only holes or only electrons are involved in the flow of current.

The following types of field-effect transistor are used:

- Junction-gate field-effect transistor
- Insulated-gate field-effect transistor
- Metal oxide semiconductor field-effect transistor (MOSFET)

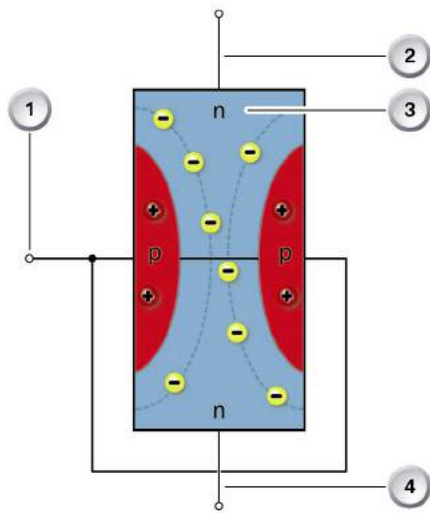

Index	Explanation
1	Gate
2	Drain
3	N-channel
4	Source

Structure of a field-effect transistor

The N-channel of the FET shown above is the conductive area. The electric field is influenced by a voltage applied at the control electrode (gate). The flow of current through the conductive channel of the field-effect transistor is controlled by the electric field.

The barrier junction (space-charge zone) expands when the gate voltage is increased. The current through the N-channel is constricted and therefore decreased.

The barrier junction becomes smaller and the current through the N-channel greater by reducing the gate voltage. Varying the width of the barrier junction requires virtually no power.

Therefore, only a low blocking-state current flows which cannot be prevented due to the intrinsic conductivity of semiconductor crystals.

FETs are used as switches and constant current sources due to the low power consumption and the possibility of switching high currents.

The following graphic symbols are used for MOSFET:

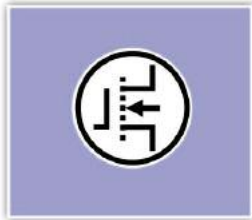

69 - Graphic symbol for MOSFET non-conducting, n-channel



70 - Graphic symbol for MOSFET non-conducting, p-channel

PTC and NTC Resistors

The considerable temperature sensitivity of semiconductors is utilized in temperature dependent resistors.

Such resistors are known as NTC resistors (Negative Temperature Coefficient) and PTC resistors (Positive Temperature Coefficient).

NTC Resistor

NTC resistors are semiconductor resistors whose resistance decreases as temperature increases. They have a strongly negative temperature coefficient.

The diagram shows the resistance progression on an NTC resistor as a function of temperature.

The most important characteristic value of an NTC resistor is the resistor R_{20} , denoting its resistance at 20 °C, i.e. the resistance of the NTC when cold.

To compensate for internal temperature effects, an NTC resistor is operated with low current so that the ambient temperature is a decisive factor governing the resistance.

The following graphic symbol is used for the NTC resistor in circuit schematics

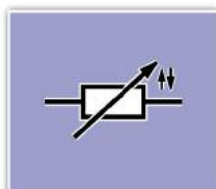
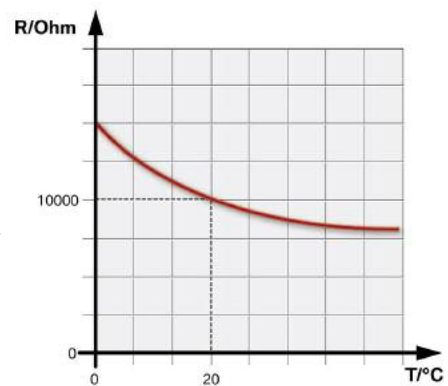

The opposing arrows represent the inverse relationship between resistance and temperature. (High temperature --> low resistance Low temperature --> high resistance)

NTC resistors with no intrinsic increase in temperature are used as sensors for measuring temperature. They are also used to stabilize temperatures in analogue circuits.

PTC Resistors

PTC resistors are semiconductor resistors whose resistance increases with rising temperature.

The following diagram shows the resistance progression on an PTC resistor as a function of temperature.

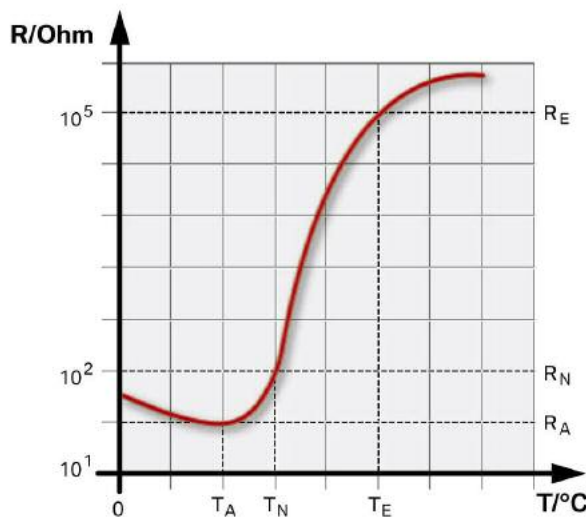

Index	Explanation
TA	Initial temperature
TN	Nominal temperature
TE	Final temperature
RA	Initial resistance
RE	Final resistance

73 - Characteristic resistance progression of an PTC resistor

The resistance begins to increase at the initial temperature T_A . This point is the initial resistance R_A . The resistance increases nonlinear up to the nominal temperature T_N . The resistance increases substantially as from the nominal resistance R_N . The operating range of the PTC extends up to the final temperature T_E .

The following graphic symbol is used in schematic circuit diagrams.

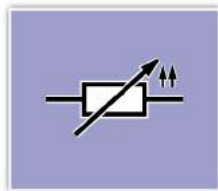

Similar to NTC resistors, PTC resistors are used as temperature sensors, e.g. in air conditioning systems.

Capacitors

The capacitor is a component that can store electrical charge or electrical energy.

The simplest form of a capacitor consists of two opposing metal plates with an insulator between them.

Capacitors store electrical energy in an electrical field. Corresponding to their design, a differentiation is made between:

- Non-polarized capacitors
- Polarized capacitors

They are used for smoothing rectified voltages and for the purpose of creating time delays.

The storage capacity of a capacitor is referred to as electrical capacitance. The unit of measure for capacitance is Farad (F).



Left: Non-polarized capacitor
Right: Polarized capacitors

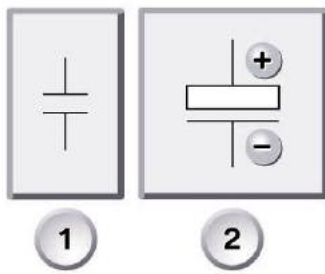

Index	Explanation
1	Non-polarized capacitors
2	Polarized capacitors

Non-polarized or polarized capacitors are used depending on the application.

In non-polarized capacitors, both connections are equivalent, i.e. they can be interchanged. Non-polarized capacitors can be used with direct and alternating voltage.

Polarized capacitors, on the other hand, have a positive and a negative connection. The two connections must not be interchanged.

Polarized capacitors must not be used with alternating voltage.

Charging and Discharging a Capacitor

The circuit below illustrates the charging and discharging procedures in a capacitor.

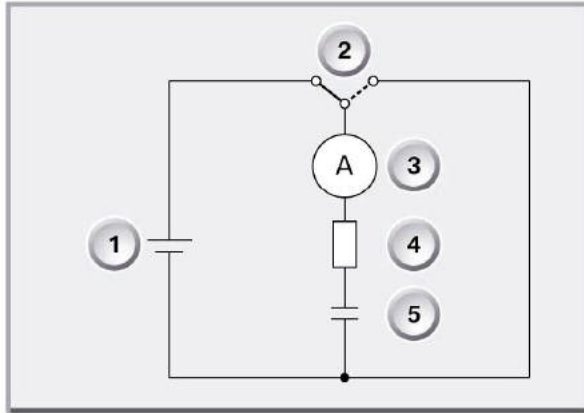

Index	Explanation
1	Direct voltage source
2	Switch
3	Ammeter
4	Resistor
5	Capacitor

Electrical charges are displaced when a direct voltage source is applied to the capacitor by closing the switch. A surplus of electrons occurs on the one plate (negative charge) while a deficit of electrons occurs on the other plate (positive charge).

Consequently, a charge current flows until the capacitor is fully charged. The current flow can be determined with an ammeter.

When the capacitor is fully charged, current no longer flows (ammeter shows 0 A) even when the voltage source remains connected.

The capacitor then blocks the direct current, i.e. the resistance of the capacitor becomes infinitely great.

The capacitor remains charged after it is disconnected from the direct voltage source, i.e. the differential between the electrons prevails between the plates.

The capacitor stores the electrical energy.

A discharge current flows in the opposite direction when the capacitor is short-circuited by flicking the switch. The discharge current flows until both plates are electrically neutral again or until the electrical energy in the resistor has been converted to thermal energy.

The following diagram shows the voltage and current progression of the current while charging/discharging the capacitor.

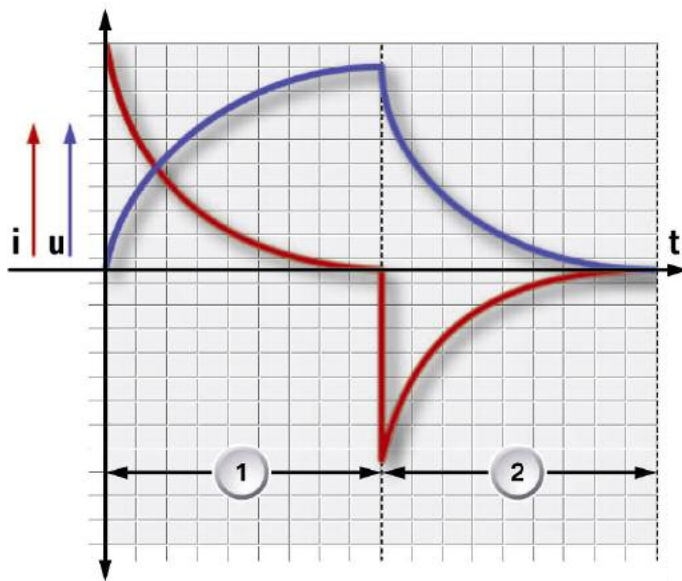

Index	Explanation
1	Charging the capacitor
2	Discharging the capacitor
i	Current
u	Voltage

Initially, high current flows during the capacitor charging procedure. On the other hand, the voltage is initially low or equals 0 V. As the capacitor charges up, the current decreases and the voltage increases. Current no longer flows when the capacitor is fully charged. The voltage reaches the value of the voltage source.

Initially, when the capacitor is discharged, high current flows but in the opposite direction of charging. Initially, the voltage is at its maximum value but constantly drops as the capacitor is discharged. Current no longer flows when the capacitor is fully discharged and there is no difference in potential between the plates of the capacitor.

If the number of charge and discharge cycles is increased per unit of time, e.g. by applying alternating voltage, the number of charging and discharging currents per unit of time will increase so that the mean value of the current per unit of time also increases. As a result, the current in the capacitor is greater, i.e. the resistance of the capacitor is apparently less (capacitive reactance).

Note: Capacitors are used in motor vehicles as short-term charge storage facilities for smoothing voltages and for minimizing overvoltage peaks.

Capacitance

The ability of a capacitor to store electricity is referred to as capacitance. The unit of measure for capacitance is Farad (F).

Capacitors used in practical applications have values that are less than one Farad:

- 1 mF = 10^{-3} F (mF = millifarad)
- 1 μ F = 10^{-6} F (μ F = microfarad)
- 1 nF = 10^{-9} F (nF = nanofarad)
- 1 pF = 10^{-12} F (pF = picofarad)

Charge and Discharge Time of a Capacitor

The value of the resistor, through which the charge current of the capacitor flows and the value of the capacitor are required for the purpose of calculating the charge and discharge time. The level of the applied voltage has no influence on the charging time.

Charging takes place faster the smaller the capacitance of the capacitor C and the smaller the resistance R.

The product of capacitor C and resistor R is therefore defined as a time constant τ (tau).

$$\tau = R * C$$

A capacitor charges or discharges at a rate of 63 % of the applied or charged voltage within each time constant τ (tau). A capacitor is almost fully charged or discharged after 5 time constants.

Resistors

Resistors limit the current flow in a circuit. The resistor is used in a circuit to introduce a desired amount of resistance into the circuit.

Resistors are available in fixed resistance or variable resistance. Fixed resistors are color coded to indicate their resistance.

In view of the fact that the resistance of power supply lines is an undesirable effect in the majority of cases, in electronics it is often necessary to limit the current in a current circuit to a defined value. Resistors are used for this purpose with their type and size depending on the respective application.

Since resistors are often very small and their value cannot be printed on the component or is difficult to read off, the rating is often indicated by colored rings. Each color represents a certain value so that the resistor rating can be determined by adding the individual values of the rings. The value indicated on the resistor applies only at a temperature of 20 °C. This restriction is necessary as the resistance of various materials changes with temperature.

Resistor Color Code Guide

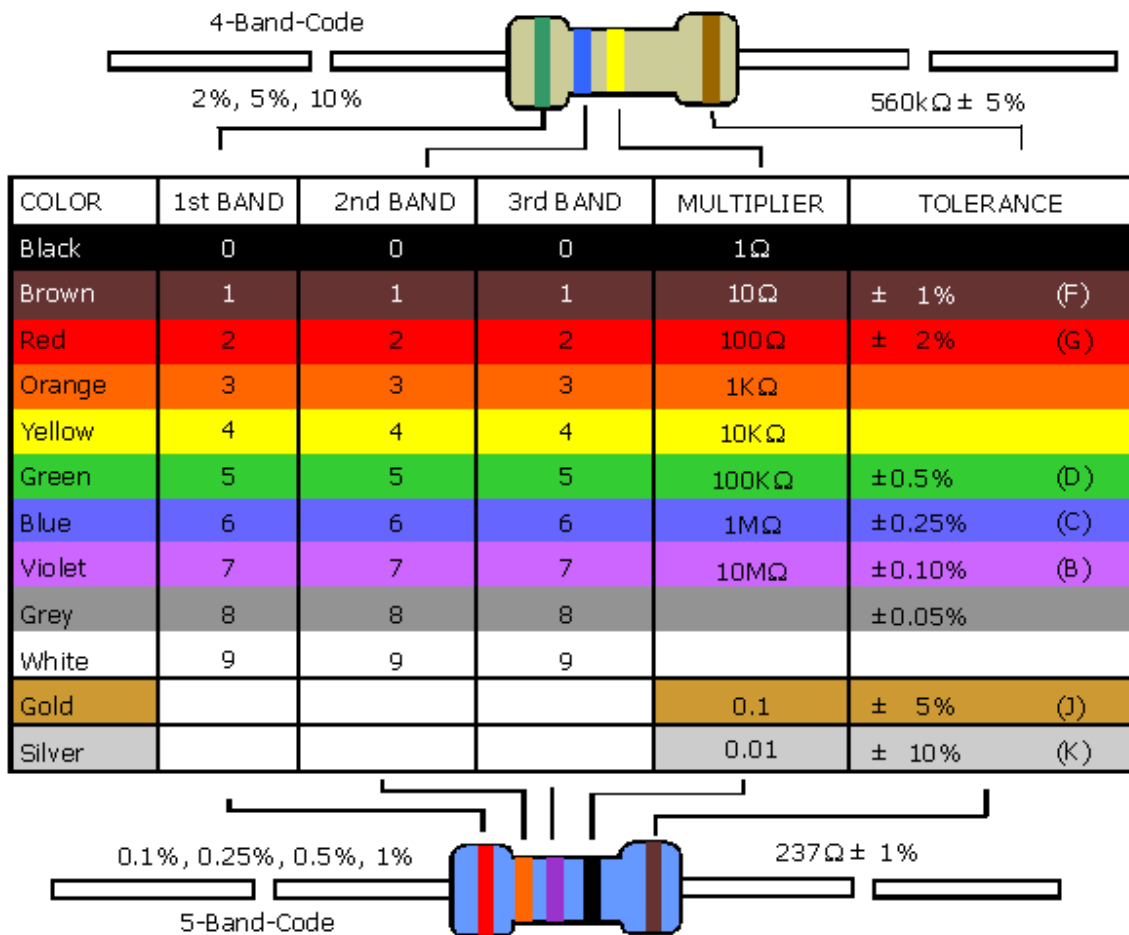

Variable Resistors

Thermistor

The resistance of materials can vary with changes in temperature; therefore, resistors can have a changing resistance value dependent on temperature.

A Thermistor is a resistor that can achieve large changes in resistance with small changes in temperature.

Thermistors are normally of the NTC (negative temperature coefficient) type. As the temperature increases the resistance decreases.

(See NTC and PTC resistors section for more information)

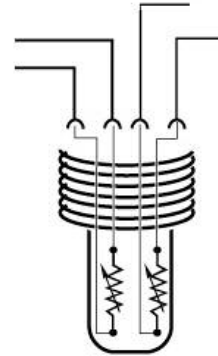

Engine Temp Dual Thermistor

Potentiometer

A Potentiometer (pot) is a variable resistor capable of changing resistance values.

Potentiometers have three terminals. One of the terminals is supply voltage, usually 5 volts. One of the terminals is the control module ground, and the third terminal is for the input signal into the control module. (Output from the Pot.)

Potentiometers are used to measure mechanical movement. (e.g. EDR feedback)

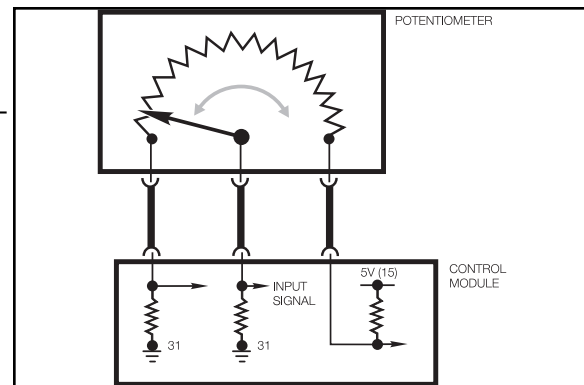

Potentiometer

Rheostat

A Rheostat is similar in operation to a potentiometer except a Rheostat only has two connectors. This arrangement allows the resistance to be varied between those two connectors.

Integrated Circuits

An integrated circuit (IC) is an electronic circuit consisting of transistors, capacitors, resistors and inductances that is fully integrated in or on one single piece of semiconductor substrate.

Modern integrated circuits such as memory chips can contain several hundred millions of components (especially transistors).

Up until the 1950s, electronic circuits featured a discrete layout, i.e. the individual components such as resistor, capacitor, coil, diode ... were soldered on to pc-boards (pcbs) and interconnected by wires or printed conductors.

The first integrated circuits in series production were introduced in the early 1960s and simply consisted of up to 30 to 40 transistors.

Today's processors consist of almost 100 million transistors covering an area of little more than one square centimeter. Memory chips contain a billion transistors on the same area.

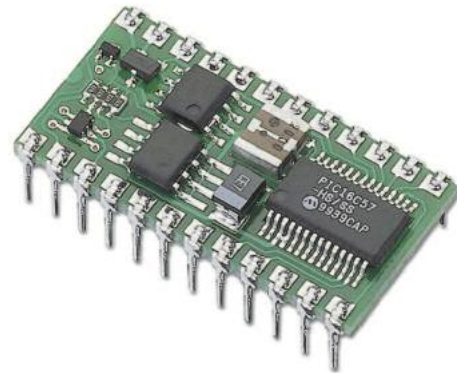

Several ICs are combined to form an integrated circuit

Integrated Circuit Manufacturing

The base material (substrate) of the majority (more than 99 %) of integrated circuits is silicon which is also the active material for transistors. Other materials such as gallium arsenide are used for very high volume or optical applications. Integrated circuits are produced industrially in large quantities. They are produced in an extremely clean environment, in so-called clean rooms with a very low density of dust particles. This is necessary as even the smallest particles ($< 0.1 \mu\text{m}$) can cause a complete circuit to fail.

Control Units

Control units are electronic modules which are mainly installed in locations where something needs to be controlled or regulated. In motor vehicles, control units are used in all conceivable electronic applications. Control units are also used for the purpose of controlling machines, installations and other technical processes, e.g. engine control unit.

In the early years of electronic engine control, control units were mainly used for ignition systems. Since 1987, they have also been used for electronic control of diesel engines.



Control units generally operate in accordance with the input-processing-output principle (IPO). Sensors provide the input data by determining a physical variable such as engine speed, pressure, temperature, etc.

This value is compared to a specified value entered or calculated in the control unit. If the measured value does not agree with the stored value, the control unit adjusts the physical process with the aid of actuators so that the measured actual values agree with the target values. The actuators therefore intervene in a corrective function in the current process.

Today's control units are interconnected by means of various system busses (CAN, byte-flight). The control units use the busses to exchange information relating to the operating statuses and other relevant data in the vehicle.

Today there are more than 60 control units installed in a vehicle such as the E60 (and rising).

Purpose of Electronic Signals

Electronic signals move information much like cars move passengers down the highway. It would be difficult to get to work without transportation, and there would be no transportation without signals.

Signals allow devices (e.g. sensors or switches) to communicate with control modules (either complicated processors or simple relays) which in turn perform or request (through more signaling) other functions to be carried out.

Signals inform the Climate Control of the outside air temp or tell the brake lights the right time to illuminate.

The use of electronic signals goes far beyond the basic application of electron flow to control components, enabling complex information to be passed from one component to another.

The data (input or output) is conveyed through various forms of changing voltages, resistances, current or frequency modulation.

Signals are divided into TWO main groups:

- AC type signals

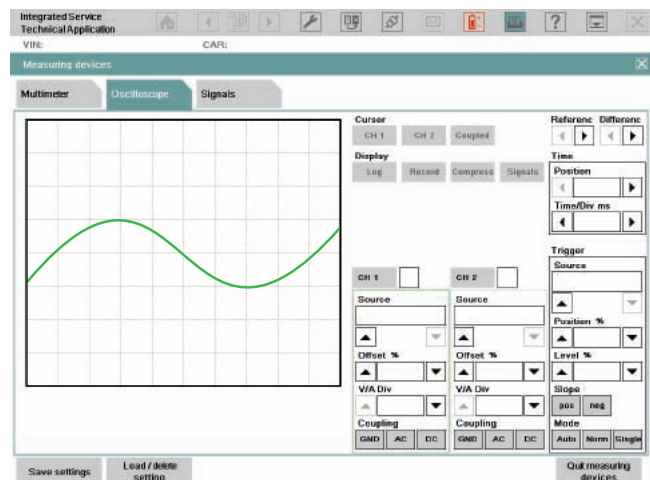

- DC type signals

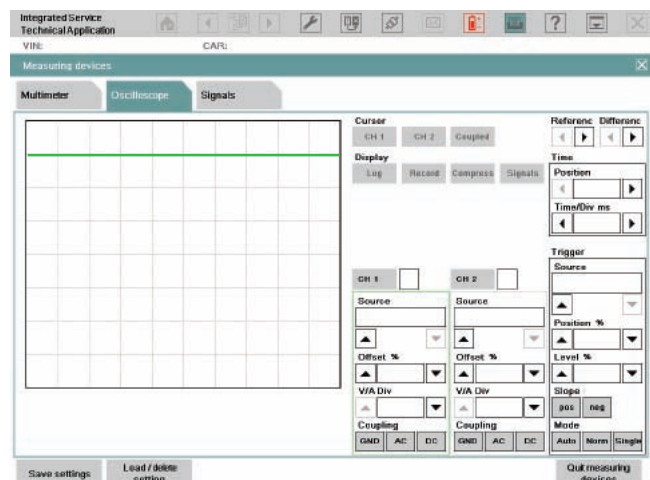

AC Voltage Signals

Inductive Signals (Induced Voltage)

Inductive sensors produce an AC Sine Wave signal. The AC voltage is induced by the shifting of a magnetic field. The sensor consists of an impulse wheel (the moving part) and a coil wound magnetic core (the stationary part).

As each tooth of the impulse wheel approaches the sensor tip, the magnetic field of the sensor shifts toward the impulse wheel and induces a voltage pulse in the windings.

As the teeth move away from the sensor, the magnetic field shifts back inducing a voltage pulse in the opposite direction.

This shifting of the magnetic field produces an alternating current (positive to negative).

Control modules which receive this alternating current, count the impulses (shifts from positive to negative) and interpret the speed of rotation of the impulse wheel.

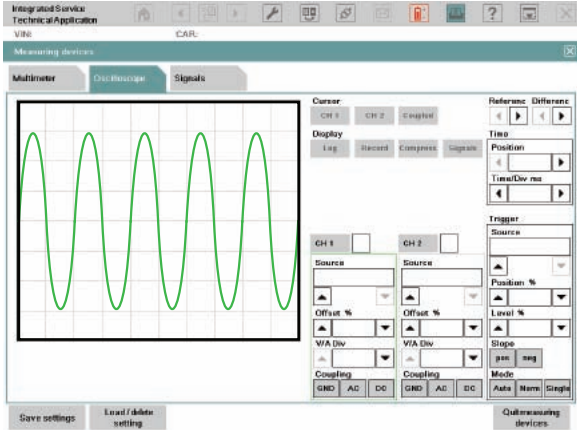
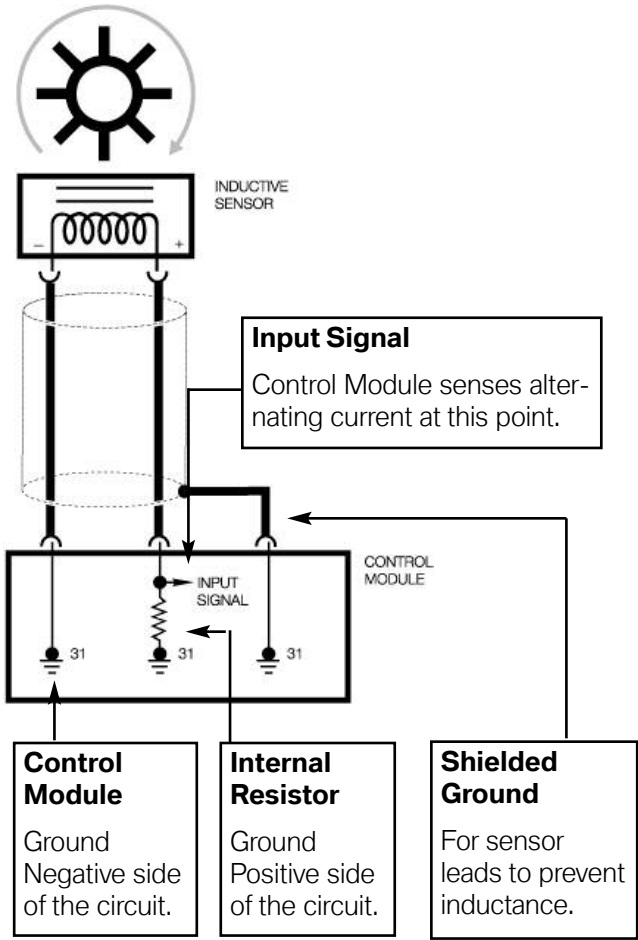

**Note: Voltage levels are dependent on sensor design.
Not all inductive sensors produce 12 volts.**

DC Voltage Signals

Five Types of DC Voltage Signals Are Used:

- Analog Signals
- Digital Signals
- Designated Value Signals
- Coded Ground Signals
- Transistor Signals

DC voltage signals are based on either 5 volts or 12 volts.

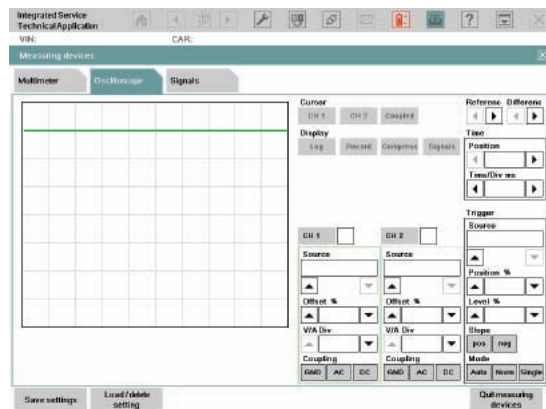

DC Analog Signals

Analog signals transmit information through an electrical circuit by regulating or changing the current or voltage.

The voltage of the signal has no fixed value. The value may be anywhere in the operating range of the signal.

Three sources of analog signals are:

- NTC Sensors
- PTC Sensors
- Potentiometers

DC Analog Sensors

NTC Sensors

NTC (Negative Temperature Coefficient) sensors change resistance based on temperature.

As the temperature goes up the resistance goes down. This decrease in resistance causes the voltage drop across the sensor to decrease and the input signal voltage at the control module decreases.

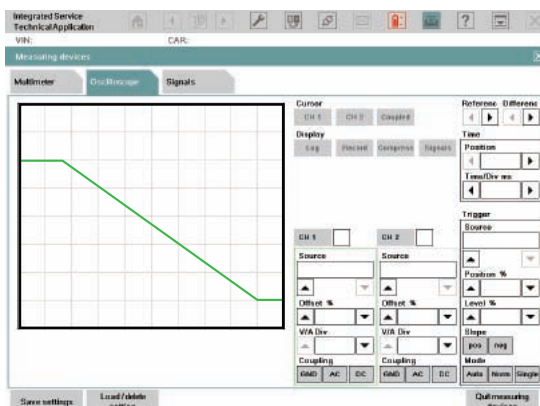

Typical NTC Sensor Signal

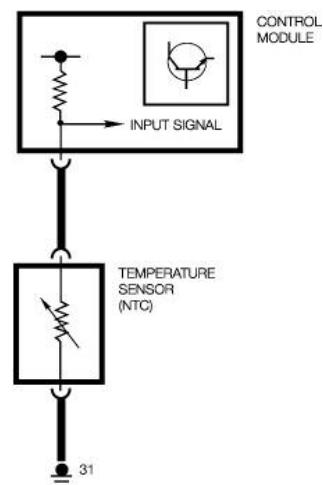

PTC Sensor

PTC (Positive Temperature Coefficient) sensors also change resistance based on temperature. In a PTC sensor as the temperature goes up the resistance also goes up. The increase in resistance causes the voltage drop across the sensor to increase and the input voltage signal at the control module increases.

When troubleshooting a faulty input display, the input signal must be verified as “good” BEFORE the control module is replaced.

When checking a NTC Sensor look for these voltages and problems:

- 0v = no supply voltage or shorted to ground.
- 2v = sensor is indicating a warm condition for system being measured.
- 4v = sensor is indicating a cold condition for system being measured.
- 5v = sensor or wiring harness is open.

Note: Remember a PTC type sensor will indicate opposite results on intermediate readings (i.e. 4 volts = warm).

Typical Application of NTC Type sensor:

- Engine Coolant Temp Sensor
- Transmission Temp Sensor
- T-MAP Sensor
- IHKA interior air temp sensor

Note: For more information see the NTC and PTC resistor section of this training material.

Notes: _____

Potentiometers

A Potentiometer produces a gradually changing voltage signal to a control module. The signal is infinitely variable within the operating range of the sensor.

This varying voltage reflects a mechanical movement or position of the potentiometer wiper arm and its related components.

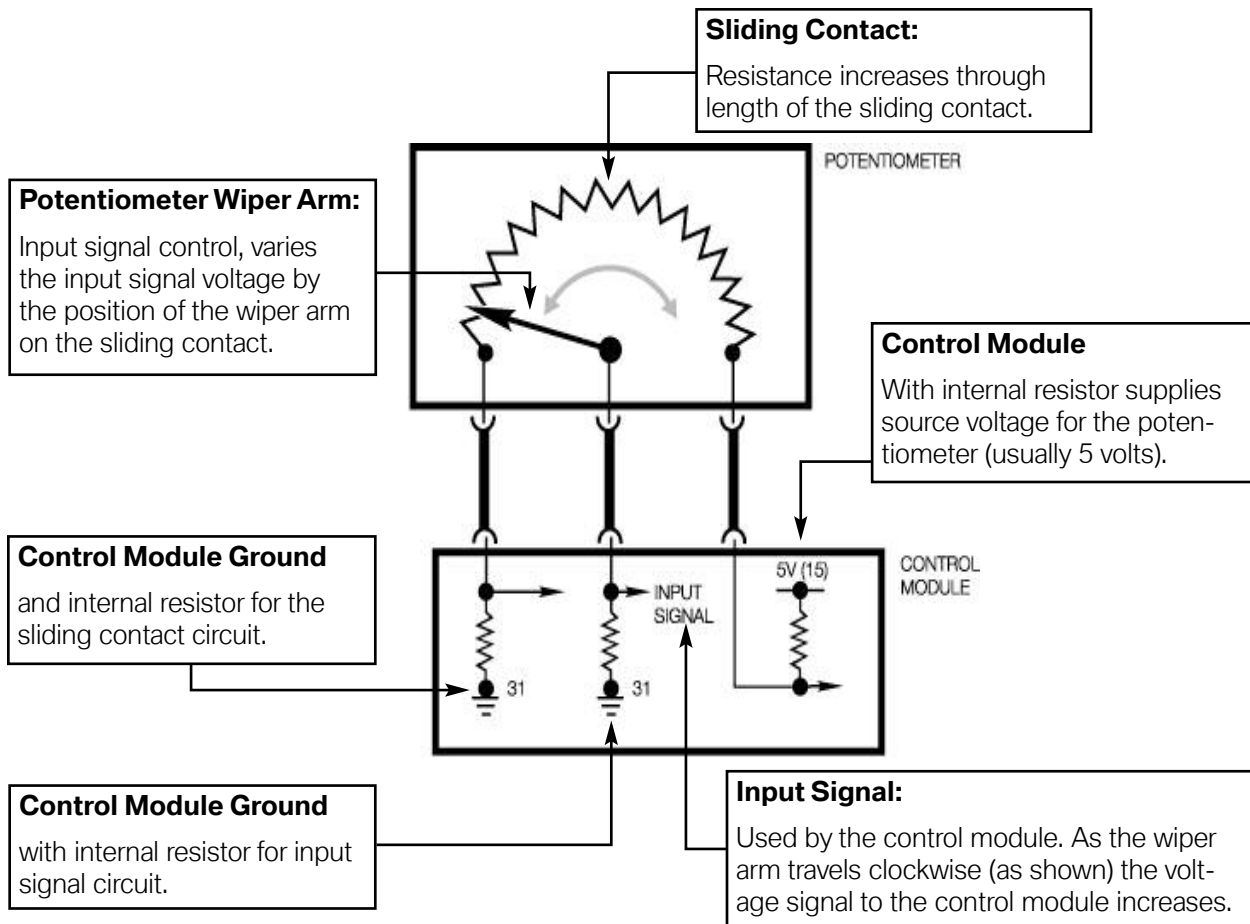

Typical Application of Potentiometers:

- Pedal Position Sensors
- Throttle Position Sensors (Also Feedback Potentiometers)

DC Digital Voltage Signals

Digital Signals transfer information through an electrical circuit by switching the current on or off. Unlike analog signals which vary voltage, a digital signal has only two possible states, control voltage or 0 voltage.

Two types of Digital Signals:

- Switched (High/Low) Signals
- Modulated Square Wave signals

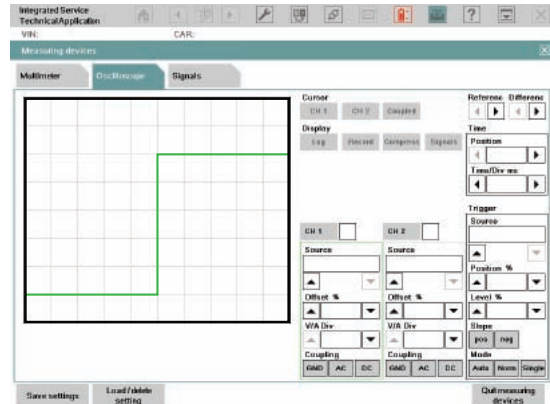

Switched B+ (High/Low) Signal

This DC voltage signal produces an ON/OFF type input to the control module. The voltage level will indicate a specific operating condition.

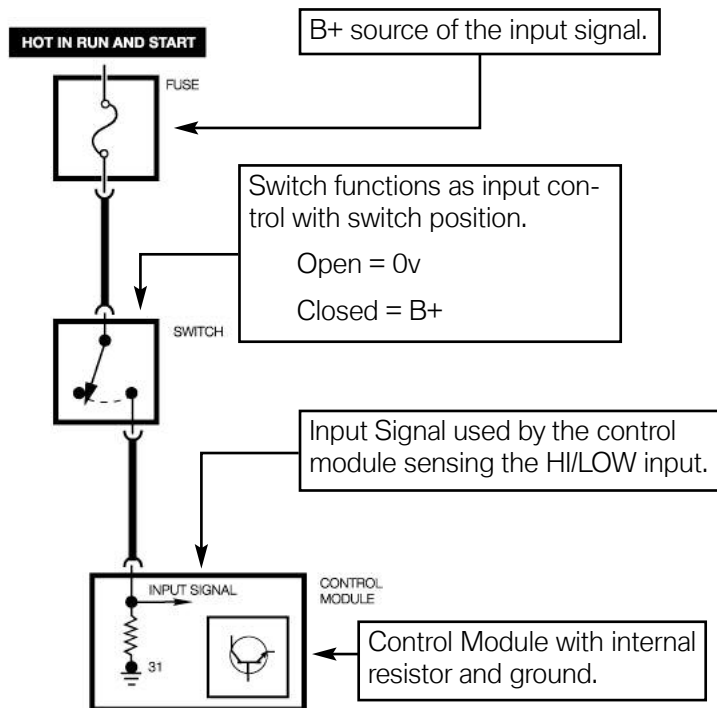

Typical Application of Switched B+

- Ignition Switch
- Light Switch
- Reed Switch
- Seat Belt Switch
- Hall Effect Switch (e.g. Brake Light Switch)

Switched B- (High/Low) Signal

This Ground Signal produces an ON/OFF type input to the control module. The voltage level will indicate a specific operating condition.

The only difference between a switched B- and a switched B+ is the voltage in which the signals are switched.

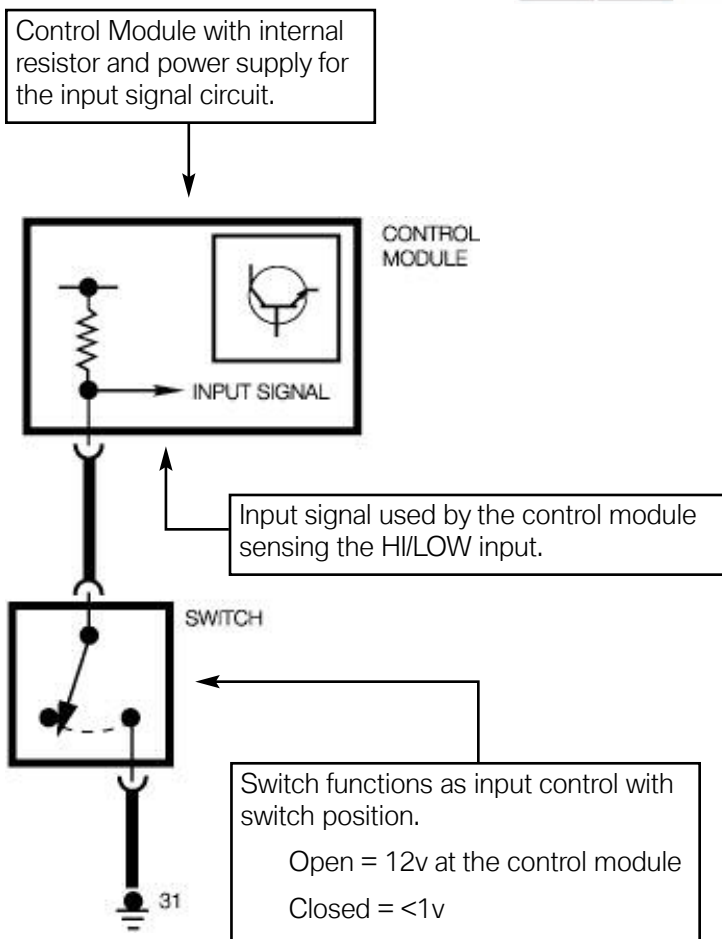
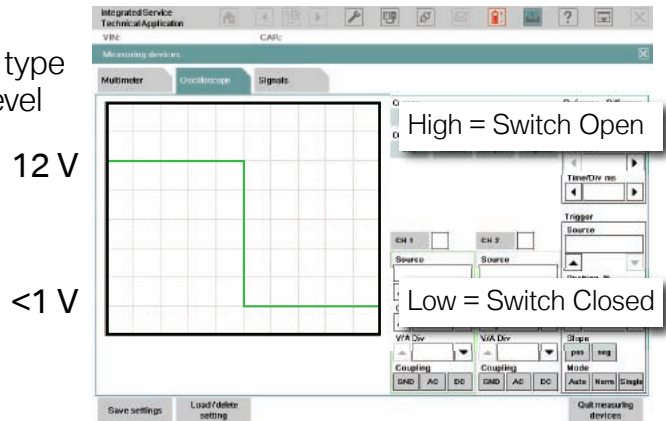

Typical Application of Switched B-

- Door Position Switch
- Window Switches
- Sunroof Switch

Modulated Square Wave

A Modulated Square Wave is a series of High/Low signals repeated rapidly.

Like the switched signals (B+, B-) the square wave has only two voltage levels.

A high level and a low level.

A modulated square wave has 3 characteristics that can be modified to vary the signal:

- Frequency
- Pulse Width
- Duty Cycle

■ Frequency

The frequency of a modulated square wave signal is the number of complete cycles or pulses that occur in one second. This number of cycles or frequency is expressed in Hertz (Hz). 1Hz = 1 complete cycle per second.

An output function may use a fixed or varied frequency.



A Modulated Square Wave appears as a High/Low signal repeated rapidly over and over.

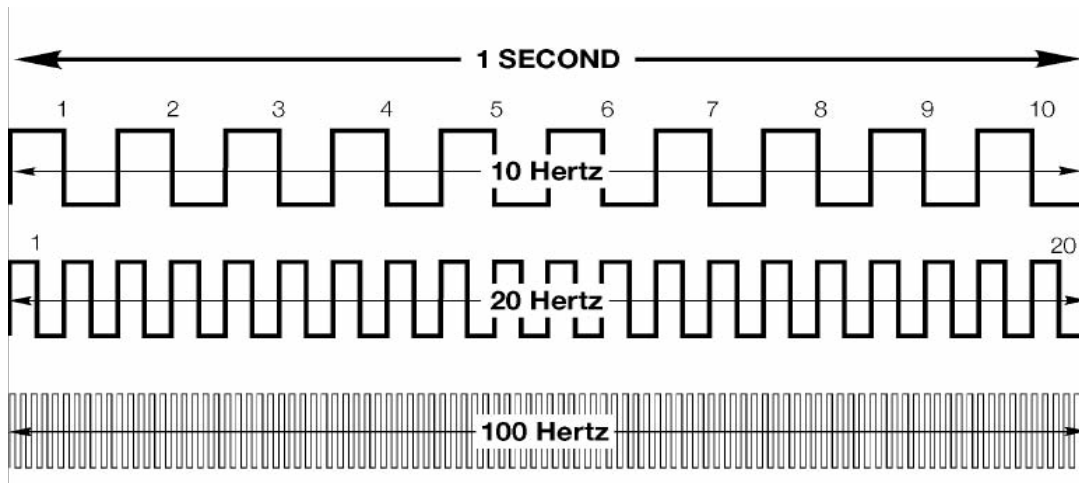

Typical Application of Fixed and Varied Frequency

Fixed Throttle command from EMS2000 to EDR

Varied Hall effect crank sensor
Hall effect wheel speed sensor
Hall effect camshaft sensor

■ Pulse Width

The Pulse Width of a signal is the length of time a pulse is on. Vehicle systems may use fixed or varied ON times/pulse width. Pulse width is expressed in milliseconds (ms).

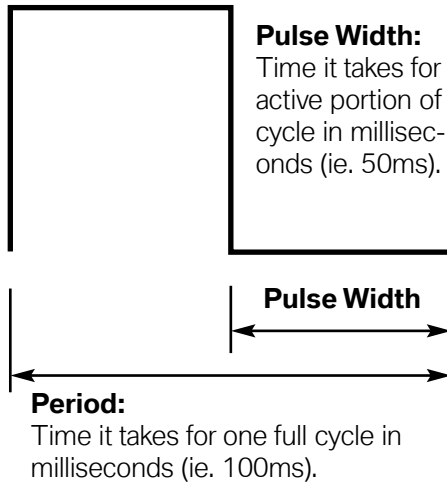

■ Duty Cycle

The Duty Cycle of a square wave is the ratio of ON time to OFF time for one cycle. Duty cycle is expressed in %.

Vehicle systems use both fixed duty cycle signals and variable duty cycle signals.

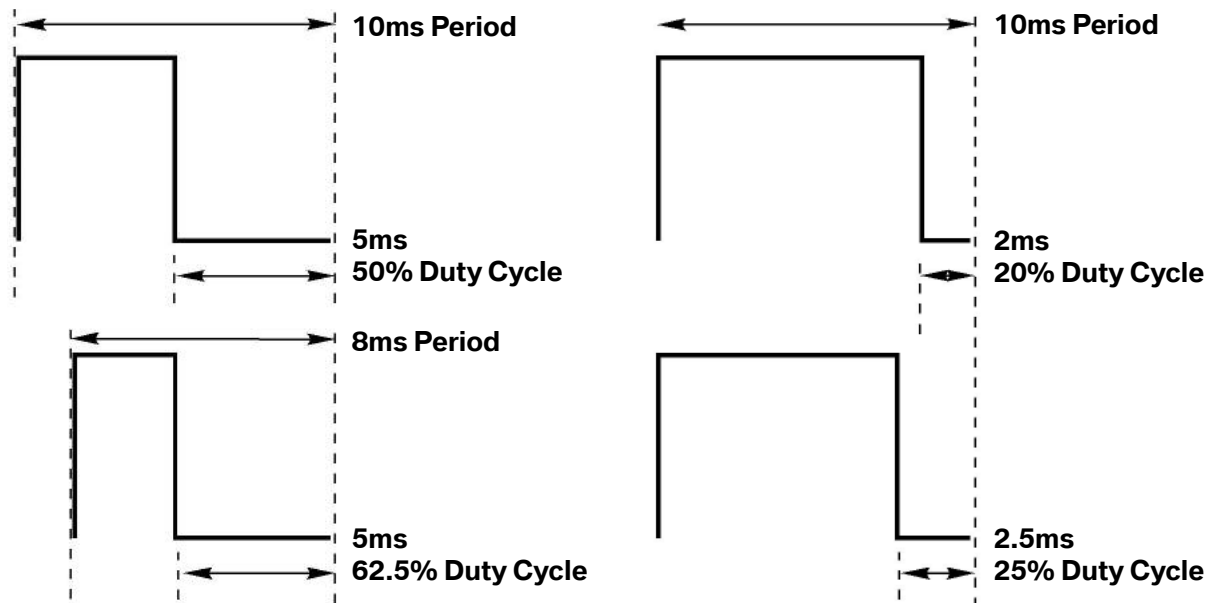

Time

1 second = 1000 milliseconds (ms)
1/4 second = 250 milliseconds
1/100 second = 10 milliseconds

1/2 second = 500 milliseconds
1/10 second = 100 milliseconds
1/1000 second = 1 millisecond

DC Digital Sensors

Hall Effect Sensors

Hall Effect Sensors can be used to produce ON/OFF signals or modulated square wave.

Hall Effect Sensors are electronic switches that react to magnetic fields to rapidly control the flow of current or voltage ON and OFF. It consists of an epoxy filled non-magnetic housing containing a hall element and a magnet, and a trigger wheel.

The Hall element is a thin non-magnetic plate which is electrically conductive. (Voltage will flow through the plate.) Electron flow is equal on both sides of the plate.

Since everything between the magnet and the hall element is non-magnetic the magnet (magnetic field) has no effect on the current flow.

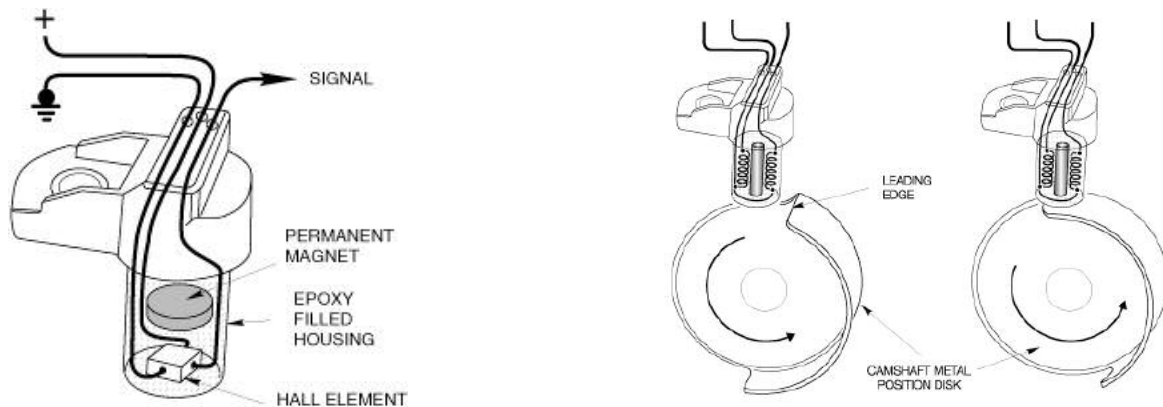

As a metal disk or solid area of a toothed wheel, flywheel or other trigger device approaches the sensor, a magnetic field is created between the magnet and the disk. This magnetic field causes the electron flow to stop on one side of the plate. Electrons continue to flow on the other side of the plate.

The Hall Sensor Signal is a measurement of the voltage drop between the two sides of the plate or element. When the magnetic field increases (disc or solid toothed area in front of sensor) the voltage drop across the two sides of the element increases. High voltage on one side, low voltage on the other. The signal output from the sensor is High.

As the disc moves away from the sensor the magnetic field weakens and is lost. The loss of the magnetic field (blank toothed or open area of the wheel in front of the sensor) produces very little voltage drop across the two sides of the element. The output signal is Low.

A rapid switching of the voltage ON/OFF produces a HIGH/LOW signal that the control module uses to recognize speed and position.

Typical Application of Hall Effect sensors

- Crankshaft Sensors
- Camshaft Sensors
- Motor Position and Speed Sensors (e.g. Window Motor, Sunroof Motor)

Magneto-resistive Sensors

The active sensing of the Magneto-resistive Sensor is particularly suitable for advanced stability control applications in which sensing at zero or near zero speed is required.

A permanent magnet in the sensor produces a magnetic field with the magnetic field stream at a right angle to the sensing element.

The sensor element is a ferromagnetic alloy that changes its resistance based on the influence of magnetic fields.

As the high portion of the pulse wheel approaches the sensing element a deflection of the magnetic field stream is created. This creates a resistance change in the thin film ferromagnetic layer of the sensor element.

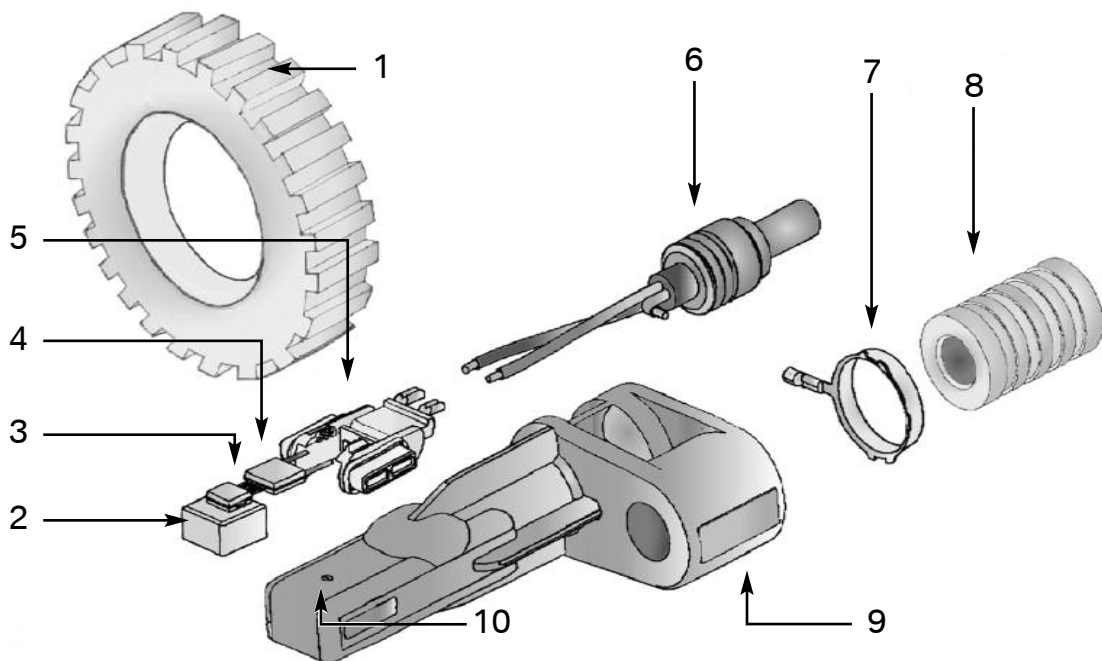

Index	Explanation	Index	Explanation
1	Metal pulse wheel	6	Sensor wiring with weather boot
2	Magnet	7	Ground contact ring
3	Sensor element	8	Fastening element
4	Evaluation module	9	Sensor housing
5	Support for the sensor element	10	Pick-up surface

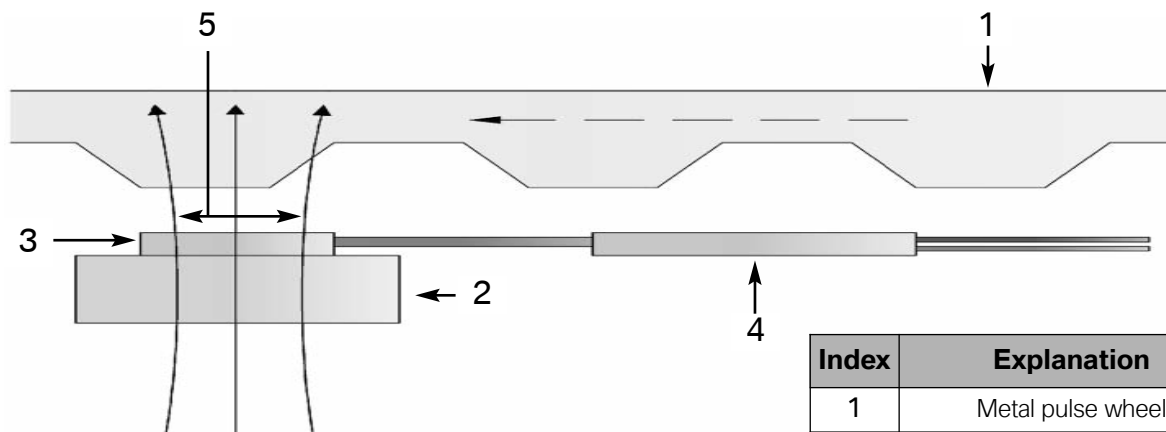

Magneto-resistive Sensor

Index	Explanation
1	Metal pulse wheel
2	Magnet
3	Sensor element
4	Evaluation circuit
5	Magnetic field

The sensor element is affected by the direction of the magnetic field, not the field strength. The field strength is not important as long as it is above a certain level. This allows the sensor to tolerate variations in the field strength caused by age, temperature, or mechanical tolerances.

The resistance change in the sensor element affects the voltage that is supplied by the evaluation circuit. The small amount of voltage provided to the sensor element is monitored and the voltage changes (1 to 100mv) are converted into current pulses by the evaluation module.

- Signal Low-7mA
- Signal High-14mA

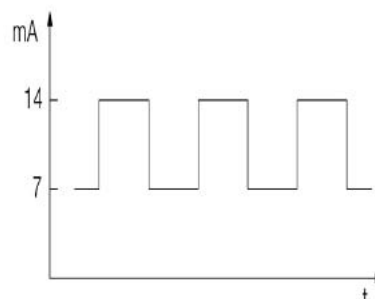

The sensor is supplied 12V by the control unit. Output voltage from the sensor is approximately 10V. The control unit counts the high and low current pulses to determine the wheel speed.

Typical Application of Magneto-resistive Sensor

- Currently used for wheel speed sensors.

Designated Value Signals

Designated values are produced through fixed resistance positions of a multi-position switch. As the switch is operated the voltage drop across the resistor(s) of each switch position causes the voltage level of the input signal to change to a predetermined voltage value.

These predetermined (designated) voltages signal the control module to perform specific functions.

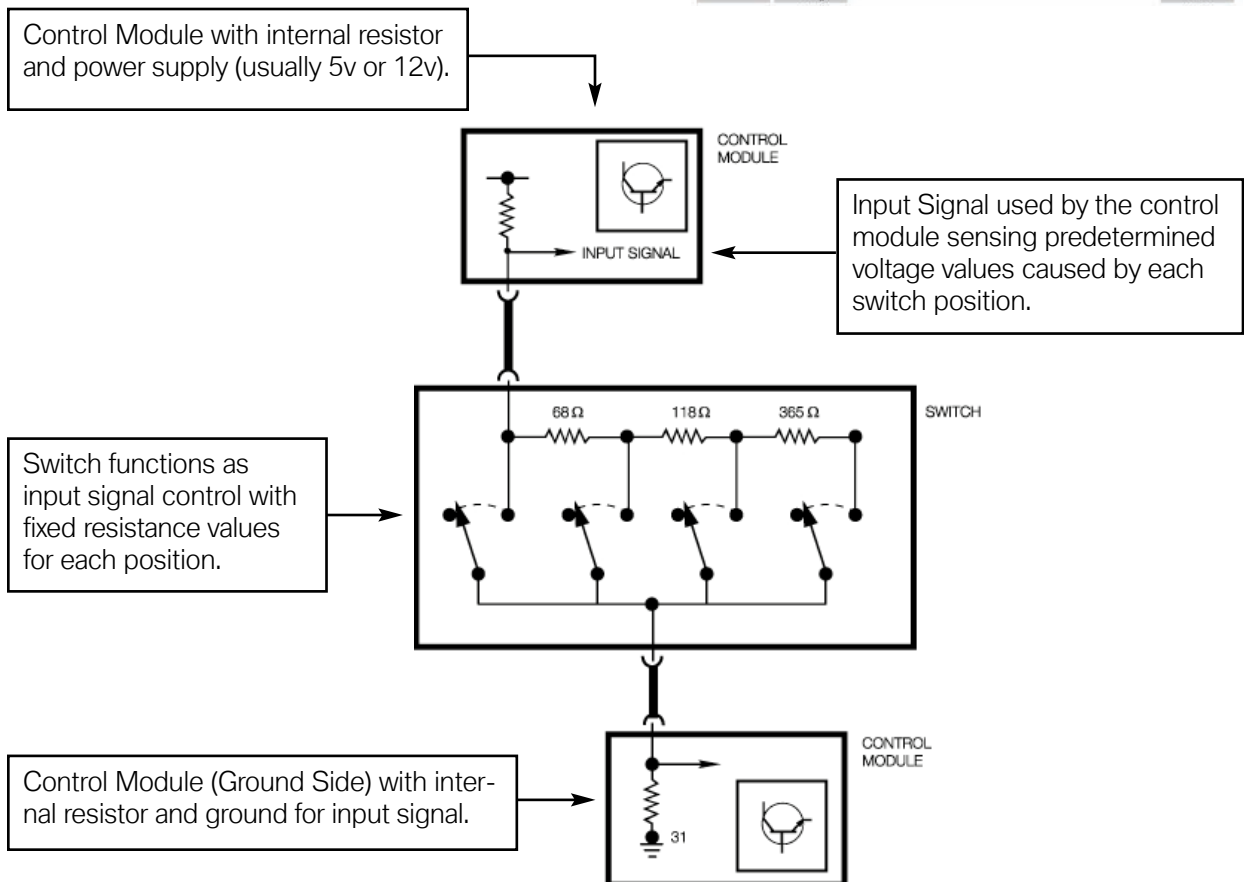
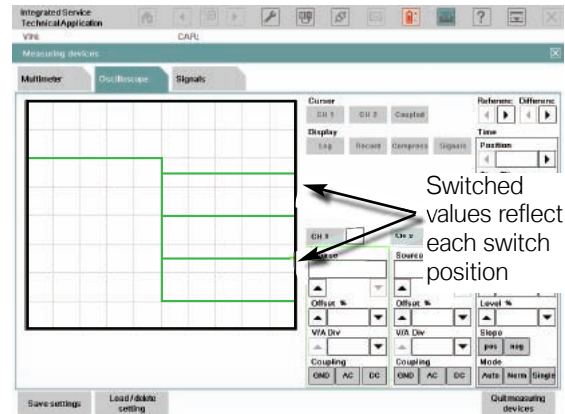

Coded Ground Signals

Coded ground signals produce a set of High/Low requests, the combination (pattern) of which is interpreted by the control module to perform a specific function.

Coded ground signals are generated through a switch or series of switches signaling the control module requests for operation.

Wiper Switch Schematic

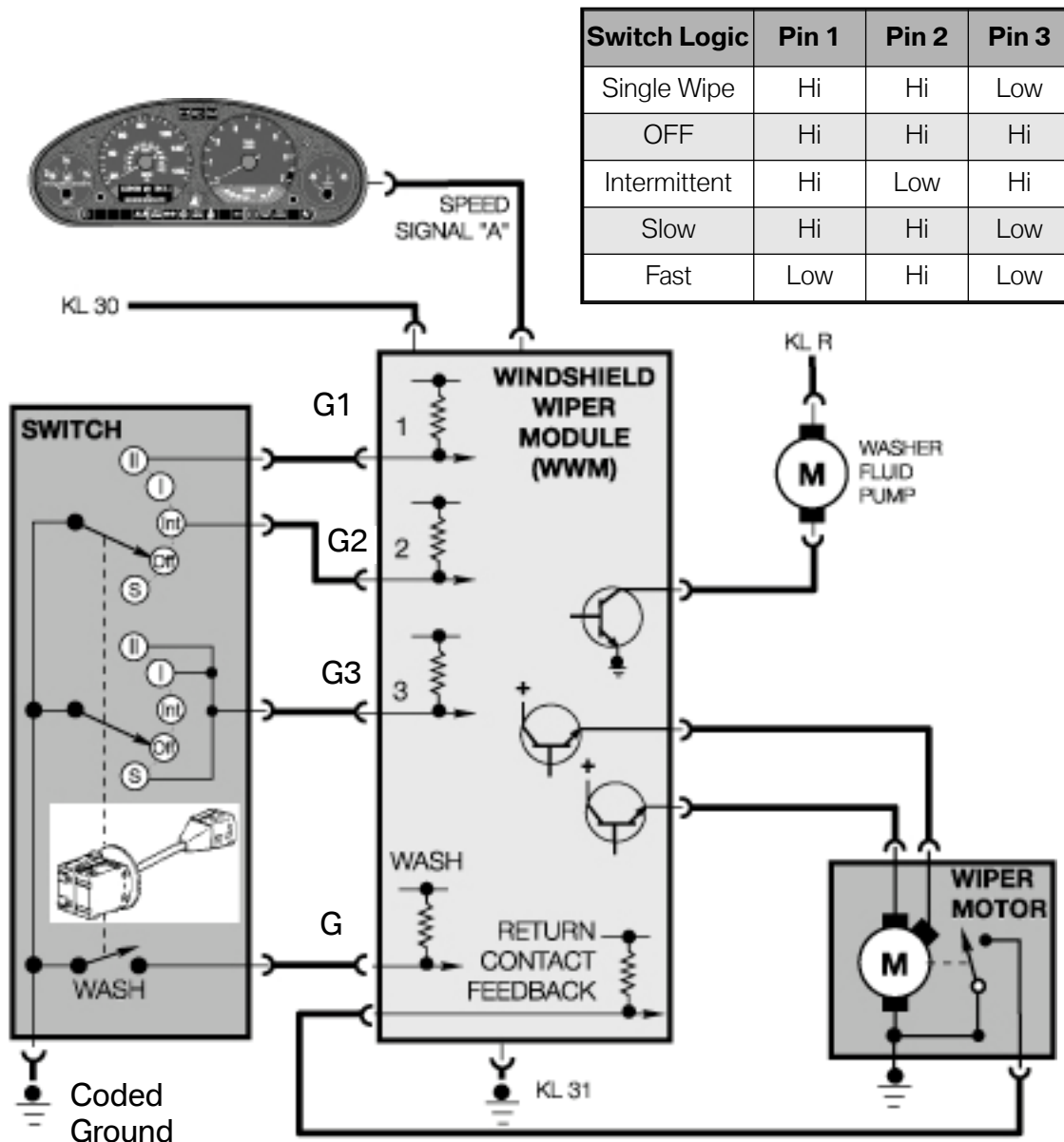

Typical Applications of Coded Ground Signals

- Wiper Switch
- Window Switch

DC Digital Input/Output Stages

Transistor Final Stage Function

The transistor takes on a number of applications that must be understood to effectively analyze a circuit. The transistor in operation functions as two parts much like a relay. Both the relay and the transistor control high currents with a low current signal.

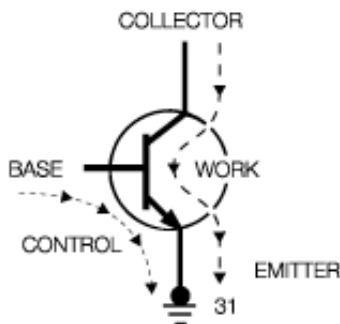

Transistor

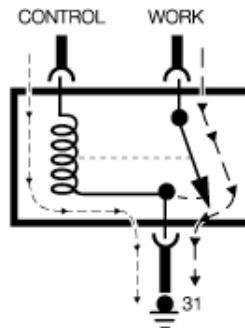

Relay

The transistor consists of three major sections:

- Base
- Emitter
- Collector

The base/emitter path functions as the control circuit activated by the control module to oversee or control the work.

The collector/emitter path functions as the work side of the circuit, supplying power or switching on the work.

In operation the transistor can either be switched ON momentarily, or supply a constant power or ground. The transistor can also be modulated or pulsed to supply a modulated square wave signal.

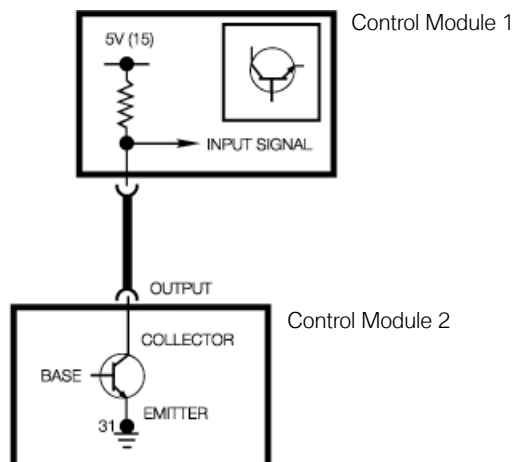

■ Modulated, Momentary, Constant B- as Input/Output

The input signal of control module 1 is an output signal of control module 2.

Control module 2 through activation of its internal transistor provides a ground input for control module 1.

The input signal at control module 1 is either a momentary/constant signal (i.e torque convertor signal from TCM to DME) or a modulated signal (i.e. vehicle speed signal ASC to DME).

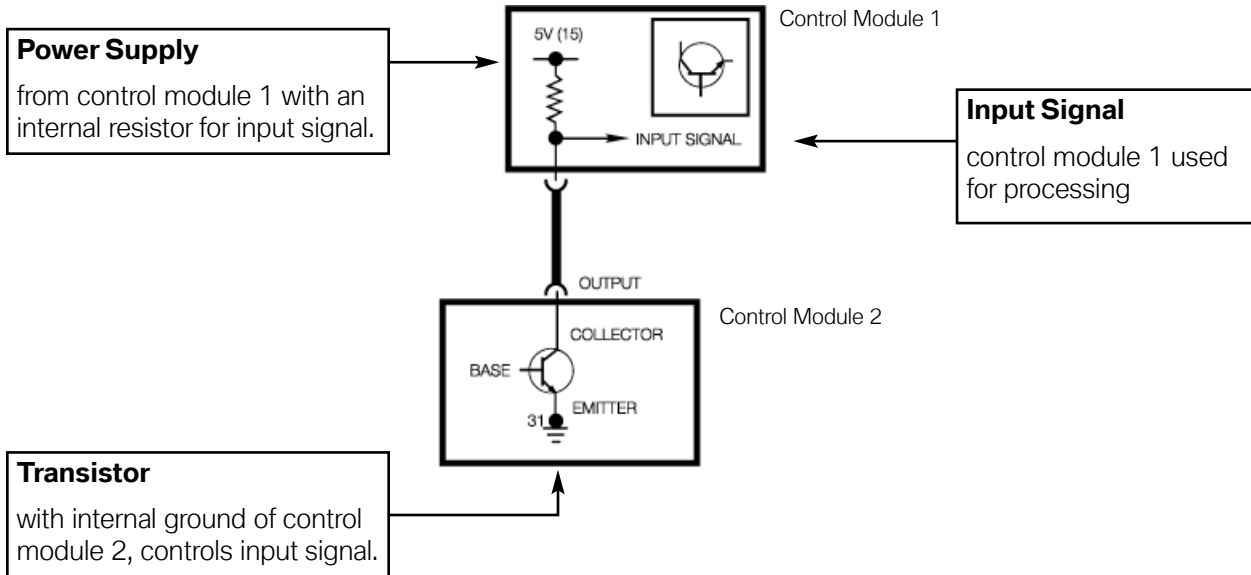

■ Momentary/Constant B+ as an Input/Output Signal

The input of control module 2 is controlled by control module 1 through internal activation of the transistor. Control module 1 provides power for the input circuit of control module 2.

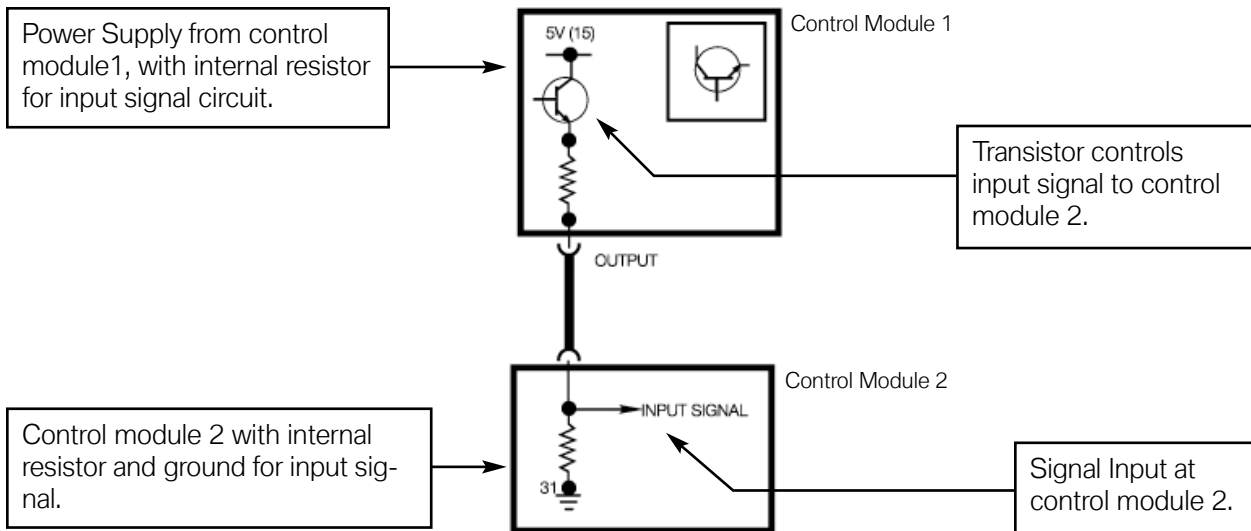

■ Constant B-/B+ to Energize a Component

Constant B-

Output function to energize a component.

Relay is energized by activation of the transistor inside the module. The transistor provides a ground for the relay coil via the control module.

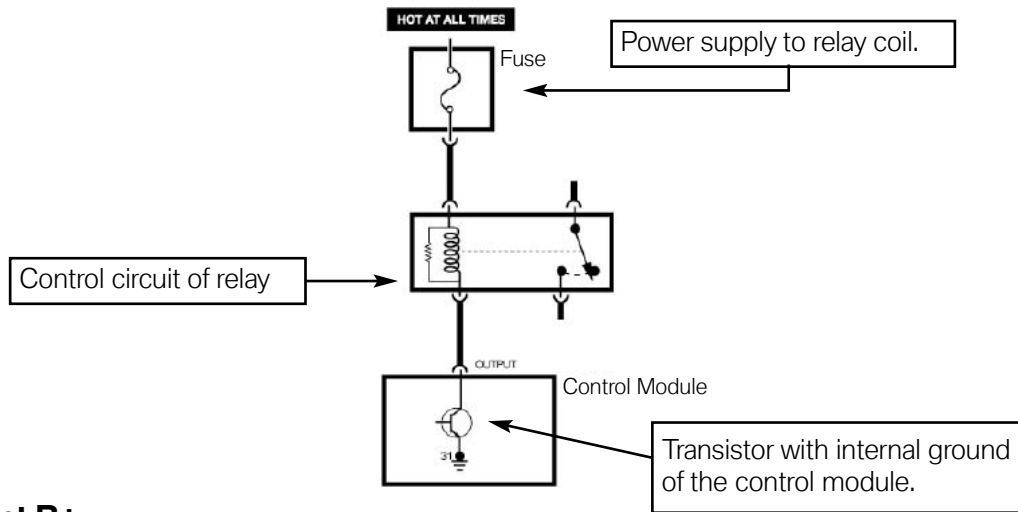

Constant B+

Control module output function to energize a component.

Transistor controls output function of the control module.

Control module supplies power to the relay.

The relay is activated by the control module through activation of the transistor which provides a ground for the relay coil.

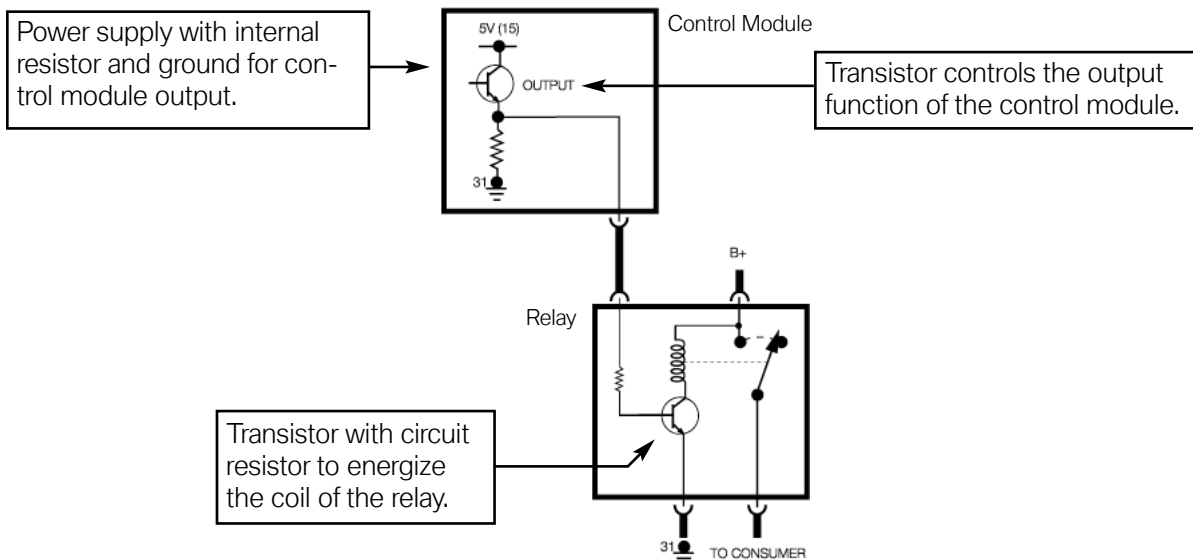

■ Modulated B-/B+ to Operate a Component

Modulated B-

Output function to operate a component.

The idle valve motor is operated by the control module through activation of the transistor which provides a ground for the open winding of the valve.

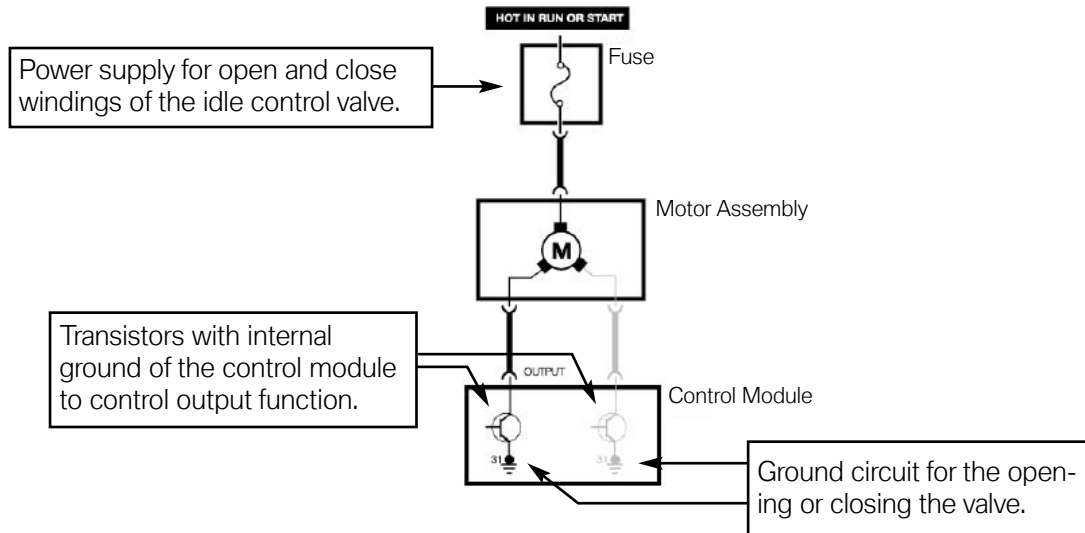

Modulated B+

Output function to operate a component.

The motor is controlled by a transistorized function of the control module, which provides a modulated voltage at a specific frequency to the motor. The throttle position is changed by altering the Duty Cycle of the pulses.

